

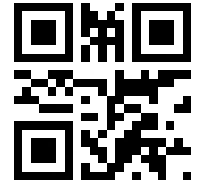

Physical Address: 4340 I-10 West - Seguin TX 78155
 Mailing Address : P.O. Box 1079 - Seguin TX 78156
 Phone: 888-798-8794 Fax: 888-377-4267

PURCHASE ORDER: PAGE 1 OF 6
DATE: 11/17/2009 TIME: 4:32 PM
CUSTOMER: Building Specials
Revision No: 5
JOB NUMBER: 681816
SALES PERSON: Brittany Shewbart



BUILDING SPECIFICATIONS

BUILDING TYPE:	Fully sheeted
WIDTH :	35'
LENGTH :	70'
FSW HEIGHT:	14'
BSW HEIGHT:	14'
ROOF SLOPE:	3.0 : 12
FRAME TYPE:	Clear span
FRAME PROFILE:	Gable
SW BAYS: 3 x 23' 4"	
LEW SHEETING:	Sheeted
REW SHEETING:	Sheeted
FSW SHEETING:	Sheeted
BSW SHEETING:	Sheeted

CUSTOMER INFORMATION:

NAME:	Building Specials
COMPANY:	ICON Building Systems
ADDRESS:	
CITY:	Seguin
ZIP:	78155
PHONE:	
CELL:	WK:
FAX:	
E-MAIL:	
PROJECT:	35x70 Special
SHIP TO:	
Seguin, Texas, 78155	
COUNTY:	Guadalupe

DESIGN LOADS AND CODES*

LIVE LOAD:	20.0
WIND LOAD:	90
BUILDING CODE:	IBC 06
GROUND SNOW:	20.0
SEISMIC COEF:	0.39
SEISMIC ZONE:	A
EXPOSURE:	B
COLLATERAL:	0.5
HIGH WIND:	
Building is not 100MPH or Higher	

WALL DATA

GAUGE:	26
PROFILE:	PBR
COLOR:	Polar White
TRIM COLOR:	Polar White
F.O. Cover Trim:	Standard
BASE TRIM:	no
BASE TYPE:	Angle
CONCRETE NOTCH:	yes
FASTENERS:	Premium
WAINSCOT:	no

INSET BAYS

LEW: no	Sheeted
REW: no	

ROOF SHEETING

GABLE EXT.

LEW: 0'	FSW: Panel shear
REW: 0'	BSW: Panel shear

WALL BRACING

EAVE EXT.

FSW: 0'	LEW: Bearing frame
BSW: 0'	REW: Bearing frame

END FRAME TYPE

ROOF DATA

GAUGE:	26
PROFILE:	PBR
COLOR:	Galvalume
TRIM COLOR:	Polar White
CLOSURE PACKAGE:	Pro-Package
SCULPTURED RAKE:	Included
SCULPTURED EAVE:	Included
SEALANT PACKAGE:	Pro-Package
FASTENERS:	Premium
UL 90 ROOF:	Included

FRAMED OPENINGS

LEW:	
REW:	
FSW: 12' x 12'	
BSW: 12' x 12'	

THIS QUOTE IS GOOD UNTIL 11/24/2009 ONLY AND MUST HAVE ALL PAPERWORK COMPLETED ON OR BEFORE ORDER DATE

Due to current steel market volatility we are not able to honor pricing beyond "order-by" dates. The current steel market is changing rapidly and we are not able to forecast when prices will stabilize. ONLY WHEN ORDER IS RELEASED FOR FABRICATION will the current/updated price be held. If the order is delayed by customer for any reason, the order is subject to re-pricing. Price of alternates will be added if checked but is not included in the proposal total. Deposit is non-refundable - please check your order for accuracy and completeness. Building Specials REV. NO.: 5



PURCHASE ORDER: PAGE 3 OF 6
DATE: 11/17/2009 TIME: 4:32 PM
CUSTOMER: Building Specials
Revision No: 5
JOB NUMBER: 681816
SALES PERSON: Brittany Shewbart

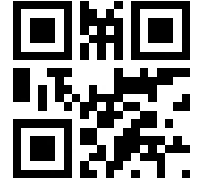

Physical Address: 4340 I-10 West - Seguin TX 78155
 Mailing Address : P.O. Box 1079 - Seguin TX 78156
 Phone: 888-798-8794 Fax: 888-377-4267

PARTION WALLS

No:	Length	Insulation Panel	Orientation	Trim		Special		Partition Wall Location
				Base	Closure	Girt Loc.		
#1								
#2								
#3								
#4								
#5								
#6								
#7								
#8								
#9								
#10								

Partition walls can have many variables. Please see the FLOOR plan of your PRELIMINARY approval drawings for the accuracy, size and location of all window and door openings on partition walls. If you have any special considerations outside of the design criteria, please consult your sales representative for more details and/or assistance. The accuracy of this quote, data and drawings are the customers' responsibility and the entirety of this document is subject to the standard terms and conditions of the contract.

CANOPIES

General notes on Canopies: The following sections for canopies are "per wall" and each wall can have the same ID for a canopy. For example, if you have one door or wall canopy on both sidewalls they will both have the ID number of "1". The sections are separated by wall and each canopy ID is listed. If you have any special considerations outside of the design criteria, please consult your sales representative for more details and/or assistance. The accuracy of this quote, data and drawings are the customers' responsibility and the entirety of this document is subject to the standard terms and conditions of the contract.

DOOR CANOPIES

LOC.	ID#	LENGTH	HEIGHT	SLOPE
LEW	DC1			
LEW	DC2			
LEW	DC3			
LEW	DC4			
LEW	DC5			
LEW	DC6			
LEW	DC7			
LEW	DC8			
LEW	DC9			
LEW	DC10			

LOC.	ID#	LENGTH	HEIGHT	SLOPE
REW	DC1			
REW	DC2			
REW	DC3			
REW	DC4			
REW	DC5			
REW	DC6			
REW	DC7			
REW	DC8			
REW	DC9			
REW	DC10			

LOC.	ID#	LENGTH	HEIGHT	SLOPE
FSW	DC1			
FSW	DC2			
FSW	DC3			
FSW	DC4			
FSW	DC5			
FSW	DC6			
FSW	DC7			
FSW	DC8			
FSW	DC9			
FSW	DC10			

LOC.	ID#	LENGTH	HEIGHT	SLOPE
BSW	DC1			
BSW	DC2			
BSW	DC3			
BSW	DC4			
BSW	DC5			
BSW	DC6			
BSW	DC7			
BSW	DC8			
BSW	DC9			
BSW	DC10			

THIS QUOTE IS GOOD UNTIL 11/24/2009 ONLY AND MUST HAVE ALL PAPERWORK COMPLETED ON OR BEFORE ORDER DATE

Due to current steel market volatility we are not able to honor pricing beyond "order-by" dates. The current steel market is changing rapidly and we are not able to forecast when prices will stabilize. ONLY WHEN ORDER IS RELEASED FOR FABRICATION will the current/updated price be held. If the order is delayed by customer for any reason, the order is subject to re-pricing. Price of alternates will be added if checked but is not included in the proposal total. Deposit is non-refundable - please check your order for accuracy and completeness. Building Specials REV. NO.: 5



PURCHASE ORDER: PAGE 4 OF 6
DATE: 11/17/2009 TIME: 4:32 PM
CUSTOMER: Building Specials
Revision No: 5
JOB NUMBER: 681816
SALES PERSON: Brittany Shewbart

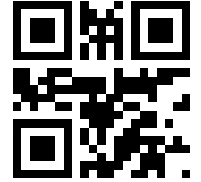

Physical Address: 4340 I-10 West - Seguin TX 78155
 Mailing Address : P.O. Box 1079 - Seguin TX 78156
 Phone: 888-798-8794 Fax: 888-377-4267

WINDOW CANOPIES

LOC.	ID#	LENGTH	HEIGHT	SLOPE
LEW	WC1			
LEW	WC2			
LEW	WC3			
LEW	WC4			
LEW	WC5			
LEW	WC6			
LEW	WC7			
LEW	WC8			
LEW	WC9			
LEW	WC10			

LOC.	ID#	LENGTH	HEIGHT	SLOPE
REW	WC1			
REW	WC2			
REW	WC3			
REW	WC4			
REW	WC5			
REW	WC6			
REW	WC7			
REW	WC8			
REW	WC9			
REW	WC10			

LOC.	ID#	LENGTH	HEIGHT	SLOPE
FSW	WC1			
FSW	WC2			
FSW	WC3			
FSW	WC4			
FSW	WC5			
FSW	WC6			
FSW	WC7			
FSW	WC8			
FSW	WC9			
FSW	WC10			

LOC.	ID#	LENGTH	HEIGHT	SLOPE
BSW	WC1			
BSW	WC2			
BSW	WC3			
BSW	WC4			
BSW	WC5			
BSW	WC6			
BSW	WC7			
BSW	WC8			
BSW	WC9			
BSW	WC10			

WALL CANOPIES

LOC.	ID#	LENGTH	HEIGHT	SLOPE	BAY(s)	LOC.	ID#	LENGTH	HEIGHT	SLOPE	BAY(s)
LEW	C1					REW	C1				
LEW	C2					REW	C2				
LEW	C3					REW	C3				
LEW	C4					REW	C4				
LEW	C5					REW	C5				
LEW	C6					REW	C6				
LEW	C7					REW	C7				
LEW	C8					REW	C8				
LEW	C9					REW	C9				
LEW	C10					REW	C10				

LOC.	ID#	LENGTH	HEIGHT	SLOPE	BAY(s)	LOC.	ID#	LENGTH	HEIGHT	SLOPE	BAY(s)
FSW	C1					BSW	C1				
FSW	C2					BSW	C2				
FSW	C3					BSW	C3				
FSW	C4					BSW	C4				
FSW	C5					BSW	C5				
FSW	C6					BSW	C6				
FSW	C7					BSW	C7				
FSW	C8					BSW	C8				
FSW	C9					BSW	C9				
FSW	C10					BSW	C10				



Physical Address: 4340 I-10 West - Seguin TX 78155
 Mailing Address : P.O. Box 1079 - Seguin TX 78156
 Phone: 888-798-8794 Fax: 888-377-4267

PURCHASE ORDER: PAGE 5 OF 6
DATE: 11/17/2009 TIME: 4:32 PM
CUSTOMER: Building Specials
Revision No: 5
JOB NUMBER: 681816
SALES PERSON: Brittany Shewbart

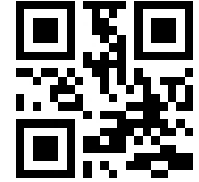

PARAPETS (note: if parapets are stepped see drawings for dimensions)

LOC.	BAY(s)	VALLEY
LEW		N/A
REW		N/A
FSW		
BSW		

MEZZANINES (note: see drawings for dimensions and location)

	X coord.	Y coord.	Width	Length	Floor Height	Floor System	Dead Load	Live Load
MEZZANINE 1.								
MEZZANINE 2.								
MEZZANINE 3.								
MEZZANINE 4.								
MEZZANINE 5.								

General Notes: the actual frame clearance for mezzanines shall not be determined until job is submitted for review. Please consult your local building department for minimum load requirements. Load requirements will change depending on the end use of the mezzanine. Example: heavy commercial storage will have a higher dead load than an office. These loads will have an impact on the overall design, foundation loads and frame sizes.

Special Mezzanine Notes:

****THIS QUOTE IS GOOD UNTIL 11/24/2009 ONLY AND MUST HAVE ALL PAPERWORK COMPLETED ON OR BEFORE ORDER DATE****

Due to current steel market volatility we are not able to honor pricing beyond "order-by" dates. The current steel market is changing rapidly and we are not able to forecast when prices will stabilize. ONLY WHEN ORDER IS RELEASED FOR FABRICATION will the current/updated price be held. If the order is delayed by customer for any reason, the order is subject to re-pricing. Price of alternates will be added if checked but is not included in the proposal total. Deposit is non-refundable - please check your order for accuracy and completeness. Building Specials REV. NO.: 5



PURCHASE ORDER: PAGE 6 OF 6
DATE: 11/17/2009 TIME: 4:32 PM
CUSTOMER: Building Specials
Revision No: 5
JOB NUMBER: 681816
SALES PERSON: Brittany Shewbart

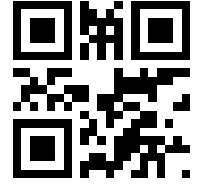

Physical Address: 4340 I-10 West - Seguin TX 78155
 Mailing Address : P.O. Box 1079 - Seguin TX 78156
 Phone: 888-798-8794 Fax: 888-377-4267

ORDER INFORMATION

DRAWING TYPE:	N.A.
DRAWING SETS:	3 SETS OF PLANS
DESIGN CALCS:	0 SETS OF DESIGN CALCULATIONS
CONCRETE DESIGN:	no (If YES full slab only - no open floor or stem wall)
DETAIL PLANS:	Included as standard

FOUNDATION TYPE (BY END USER)

CRANE LOADING:

Brackets and/or Auxillary Columns:	
Capacity (TONS)	N.A.
Runway Length (FT/M)	N.A.
(A) Runway Height (FT/M)	N.A.
(B) Runway Beam SIZE (IN/CM)	N.A.
(C) Rail Size (IN/CM)	N.A.
(D) Top of Crane to Bottom of Wheel	N.A.
Approx. Crane Span (Wheel-to-Wheel) (FT/M)	N.A.
Crane Loading Notes: Crane Systems and Runways by others. We include only the loads as specified above. Brackets or Columns are included ONLY if noted above. The above noted dimensions are approximate - under no circumstances should this information be used to order your crane(s). The use of brackets, auxiliary columns and bracing will be determined by us upon final engineering. FOR CONSTRUCTION drawings will be completed ONLY when we have received the required crane manufacturer's specifications.	

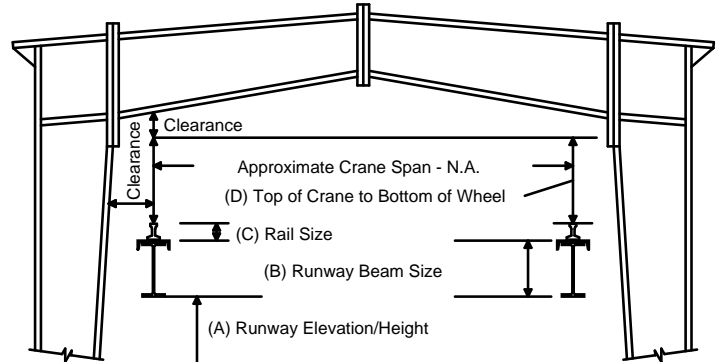

Special Job Notes: DOES NOT INCLUDE SHIPPING

WE PROPOSE TO FURNISH THE FOLLOWING MATERIALS COMPLETE IN ACCORDANCE WITH THE ABOVE SPECIFICATIONS AND GENERAL TERMS AND CONDITIONS OF CONTRACT FOR THE SUM OF:

MATERIAL F.O.B. JOB SITE - FREIGHT INCLUDED:	\$13,100.00
TEXAS SALES TAX:	Not Included
TOTAL BUILDING COST:	\$13,100.00
BUILDING DEPOSIT:	\$3,275.00
BALANCE ON DELIVERY:	\$9,825.00

****NOTE**** We do not collect tax in any State other than Texas

ACCEPTANCE OF PURCHASE ORDER

I HAVE READ AND UNDERSTAND THE GENERAL CONDITIONS OF THE CONTRACT AND HEREBY AUTHORIZE ICON TO BEGIN THE WORK SPECIFIED. THIS IS CONTRACT VALID ONLY WHEN ACCEPTED BY AN OFFICER OF ICON. BY SIGNING BELOW, I AGREE TO THE PRICES, SPECIFICATIONS, TERMS, AND CONDITIONS AS STATED IN THE GENERAL CONDITIONS OF CONTRACT AND FURTHER AGREE TO MAKE PAYMENTS AS REQUIRED BY ICON. PAYMENT: COD WITH DOWNPAYMENT. JOBS EXCEEDING \$50,000.00 SHALL REQUIRE PROGRESS PAYMENTS; JOBSITE INFORMATION MAY BE REQUIRED ON ANY JOB. THIS PROJECT IS BEING QUOTED USING MFG STANDARD SPECIFICATIONS UNLESS NOTED OTHERWISE. ACCEPTED BY BUYER AND THIS CONTRACT IS ENTERED INTO AT SEGUIN TEXAS, (GUADALUPE COUNTY) BY SUBMITTING THE PURCHASE ORDER / QUOTE FORM AND CONTRACT DOCUMENTS. I HEREBY AGREE AND ACCEPT ALL TERMS AND CONDITIONS OF SALE. FABRICATION SHALL BE IN ACCORDANCE WITH MFG STANDARD UNLESS OTHERWISE NOTED, AND WILL GENERALLY CONFORM WITHIN MANUFACTURERS CUSTOMARY TOLERANCES, AND/OR AS MODIFIED BY THE STANDARDS AND SPECIFICATIONS CONTAINED IN MFG'S PRODUCT DESCRIPTION(S). NOTE: ANCHOR RODS / BOLTS OR EMBEDMENT DEVICES ARE NOT INCLUDED AS PART OF THE SALE.

NOTE: IT IS THE CUSTOMER'S RESPONSIBILITY TO VERIFY THE LOADS & CODES WITH YOUR LOCAL OFFICIALS.

DRAWING DEPOSIT: \$3,275.00 BALANCE ON DELIVERY: \$9,825.00

Agreed to this _____ of _____, 20____
 Customer Signature
 X _____
 Printed Name

X Brittany Shewbart
 ICON Sales Representative
 CONTRACT ACCEPTED AND ENTERED INTO
 THIS _____ OF _____, 20____
 X _____
 ICON, Officer

By signing above hereby state I have confirmed all codes with my local building department and I accept full responsibility for the accuracy of the codes and loads as stated.

THIS QUOTE IS GOOD UNTIL 11/24/2009 ONLY AND MUST HAVE ALL PAPERWORK COMPLETED ON OR BEFORE ORDER DATE

Due to current steel market volatility we are not able to honor pricing beyond "order-by" dates. The current steel market is changing rapidly and we are not able to forecast when prices will stabilize. ONLY WHEN ORDER IS RELEASED FOR FABRICATION will the current/updated price be held. If the order is delayed by customer for any reason, the order is subject to re-pricing. Price of alternates will be added if checked but is not included in the proposal total. Deposit is non-refundable - please check your order for accuracy and completeness. Building Specials REV. NO.: 5

CUSTOMER:	Building Specials	
JOB NUM.:	681816	
COMPANY:	ICON Building Systems	
JOB ADDR:		
CITY:	Seguin	
COUNTY:	Guadalupe	
STATE:	Texas	
ZIP:	78155	
DATE:	11/17/2009	
PHONE:		
FAX:		
CELL:		
EMAIL:		
DWG BY:		
REV. NO.:		DATE:

APPROVAL DRAWING PACKAGE
THIS BUILDING MEETS OR EXCEEDS:
CODE/CLASS: IBC 06

Page: 1/7 Revision No: 5

BUILD FROM DRAWINGS MARKED "FOR CONSTRUCTION" ONLY!!!



Physical Address
4340 I-10 West
Seguin TX 78155
888-798-8794
888-377-4267 fax

Corporate Office
P.O. Box 1079
Seguin TX 78156
888-798-8794
888-377-4267 fax

Approval/Permit

Field locate items will not show up on drawings: personnel doors, windows, wall and sky lights along with ridge vents and other items may not show up on drawings. Please check your purchase order for these items.

Customer Signature: By signing below I am confirming that the required codes and loads are accurate and complete and that there are no additional requirements with regards to the codes, loads and/or design specifications as stated on the face of this document. All clearances for doors and hardware are the responsibility of the customer. Seller is not responsible for mechanical door clearances.

This order will begin fabrication approximately 10 days after we receive signed approval drawings. Once fabrication is started on the job revisions will not be allowed. A cashiers check for the balance due shall be due at delivery. You will be notified via DELIVERY NOTICE with the approximate date and account balance before delivery. If you wish to place your order on PERMIT HOLD please do so by checking the box below. Once a job is placed on permit hold the customer is responsible for contacting seller to release the job for fabrication. Placing a job on hold does not "lock" the price. The order shall be subject to standard terms and conditions supplied along with the quotation.



RELEASE FOR FABRICATION
NO CHANGES ARE REQUIRED



HOLD FOR PERMIT
NO CHANGES ARE REQUIRED



RELEASE FOR FABRICATION
CHANGES ARE REQUIRED &
I HAVE NOTED THE CHANGES
(SUBJECT TO VARIIFICATION)



HOLD FOR PERMIT
CHANGES ARE REQUIRED
I HAVE NOTED THE CHANGES
(SUBJECT TO VERIFICATION)



REVISE ORDER (HOLD)
CHANGES AND/OR REVISIONS
ARE REQUIRED & I WILL MAKE
CONTACT

APPROVED BY:

SIGNATURE: _____ DATE: _____

PRINT NAME: _____

DESIGN LOADS

BUILDING CODE:	IBC 06
ROOF DEAD LOAD:	2.5
COLLATERAL LOAD:	0.5
LIVE LOAD:	20.0
SNOW LOAD:	20.0
WIND SPEED:	90
WIND EXPOSURE:	B
IMP. WIND: 1	IMP. SEISMIC : 1
SEISMIC ZONE:	A
SEISMIC COEFF.:	0.39

BUILDING DESCRIPTION

NOMINAL WIDTH:	35'
NOMINAL LENGTH:	70'
B.S.W. HEIGHT:	14'
F.S.W. HEIGHT:	14'
ROOF SLOPE:	3.0 : 12

DRAWING INDEX		
CS-1	COVER SHEET	
N1	GENERAL NOTES	
S1	FRONT SIDEWALL ELEVATION	
S2	BACK SIDEWALL ELEVATION	
E1	LEFT ENDWALL ELEVATION	
E2	RIGHT ENDWALL ELEVATION	
D-	FLOOR PLAN	
FABRICATION NOTES		
MATERIALS	ASTM DESIGNATION	MIN. YIELD (ksi)
HR Steel Shapes	A572	Fy = 50
Steel Pipes	A500	Fy = 42
HSS Tubing	A500	Fy = 46
Struct. Web (pl)	A572/A1011	Fy = 50
Struct. Flange (pl)	A529/A572	Fy = 55
CF Light Gauge	A572/A1011	Fy = 50, 55
R&W Sheets	A792/A653	Fy = 50, 80
Cable Brace	A475 - Type1	EX Strong (HS)
Rod Brace	A36	Fy = 36
Mill Sections	A36	Fy = 36
MIN. TENSILE		
Machine Bolts/Nuts	A307	Fu = 60
HS Bolts 1" & <	A325 - Type1	Fu = 120
HS Bolts >1"-1.5"	A325 - Type1	Fu = 105

PLEASE PUT SAFETY FIRST!

WE HAVE A COMMITMENT TO MANUFACTURE QUALITY BUILDINGS THAT CAN BE SAFELY ERECTED. HOWEVER, THE SAFETY COMMITMENT AND JOB SITE PRACTICES OF THE ERECTOR ARE BEYOND OUR CONTROL. IT IS STRONGLY RECOMMENDED THAT SAFE WORKING CONDITIONS AND ACCIDENT PREVENTION PRACTICES ARE THE TOP PRIORITY OF ANY JOB SITE. LOCAL, STATE, AND FEDERAL SAFETY AND HEALTH STANDARDS SHOULD ALWAYS BE FOLLOWED TO HELP INSURE WORKERS SAFETY. MAKE CERTAIN ALL EMPLOYEES KNOW THE SAFEST AND MOST PRODUCTIVE WAY OF ERECTING A BUILDING. ALL EMPLOYEES SHOULD KNOW EMERGENCY PROCEDURES. DAILY MEETINGS HIGHLIGHTING SAFETY PROCEDURES ARE ALSO RECOMMENDED. THE USE OF HARD HATS, RUBBER SOLE SHOES FOR ROOF WORK, PROPER EQUIPMENT FOR HANDLING MATERIAL, AND SAFETY NETS WHERE APPLICABLE, ARE RECOMMENDED.

Sheeting & Trim	Skylights	Girt / Purlin Conditions	Girt / Purlin Type	Accessories	Quantity
Galvalume	Roof	No. Desc. LOC.	FSW: Bypass	FSW: Zee	3070 M WALKDOOR
Polar White	Wall	Roof	BSW: Bypass	BSW: Zee	
	Gutter	Wall	LEW: Flush	LEW: Zee	
	DS		ROOF: Flush	ROOF: Zee	
Polar White	Rake/Eave	Insulation			
	Corner	Description LOC.	Girt / Purlin Conditions		
		Roof	FSW: 8 "	COLOR: Red oxide	
Framing Color		Wall	BSW: 8 "	COLOR: Red oxide	
Primary Frames			LEW: 8 "	COLOR: Red oxide	
Secondary		Base Condition	ROOF: 8 "	COLOR: Red oxide	
Base		Angle			

11/17/2009 :: 4:32 PM

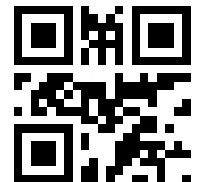

SAFETY FIRST!

WE HAVE A COMMITMENT TO MANUFACTURE QUALITY BUILDINGS THAT CAN BE SAFELY ERECTED. HOWEVER, THE SAFETY COMMITMENT AND JOB SITE PRACTICES OF THE ERECTOR ARE BEYOND OUR CONTROL. IT IS STRONGLY RECOMMENDED THAT SAFE WORKING CONDITIONS AND ACCIDENT PREVENTION PRACTICES ARE THE TOP PRIORITY OF ANY JOB SITE. LOCAL, STATE, AND FEDERAL SAFETY AND HEALTH STANDARDS SHOULD ALWAYS BE FOLLOWED TO HELP INSURE WORKERS SAFETY. MAKE CERTAIN ALL EMPLOYEES KNOW THE SAFEST AND MOST PRODUCTIVE WAY OF ERECTING A BUILDING. ALL EMPLOYEES SHOULD KNOW EMERGENCY PROCEDURES. DAILY MEETINGS HIGHLIGHTING SAFETY PROCEDURES ARE ALSO RECOMMENDED. THE USE OF HARD HATS, RUBBER SOLE SHOES FOR ROOF WORK, PROPER EQUIPMENT FOR HANDLING MATERIAL, AND SAFETY NETS WHERE APPLICABLE, ARE RECOMMENDED.

BUYER/END USE CUSTOMER RESPONSIBILITIES
MANUFACTURER HEREINAFTER REFERRED TO AS MFG
IT IS THE RESPONSIBILITY OF THE BUYER/END USE CUSTOMER TO OBTAIN APPROPRIATE APPROVALS AND SECURE NECESSARY PERMITS FROM CITY, COUNTY, STATE, OR FEDERAL AGENCIES AS REQUIRED, AND TO ADVISE/RELEASE MFG TO FABRICATE UPON RECEIVING SUCH.

MFG STANDARD SPECIFICATIONS APPLY UNLESS STIPULATED OTHERWISE IN THE CONTRACT DOCUMENTS. MFG DESIGN, FABRICATION, QUALITY CRITERIA, STANDARDS, PRACTICE, METHODS AND TOLERANCES SHALL GOVERN THE WORK WITH ANY OTHER INTERPRETATIONS TO THE CONTRARY NOTWITHSTANDING. IT IS UNDERSTOOD BY BOTH PARTIES THAT THE BUYER/END USE CUSTOMER IS RESPONSIBLE FOR CLARIFICATION OF INCLUSIONS OR EXCLUSIONS FROM THE ARCHITECTURAL PLANS AND/OR SPECIFICATIONS. IN CASE OF DISCREPANCIES BETWEEN MFG STRUCTURAL STEEL PLANS AND PLANS FOR OTHER TRADES, MFG PLANS SHALL GOVERN. (SECTION 3 AISC CODE OF STANDARD PRACTICES, 9TH EDITION)

APPROVAL OF MFG DRAWINGS AND CALCULATIONS INDICATES THAT MFG HAS CORRECTLY INTERPRETED AND APPLIED THE CONTRACT DOCUMENTS. THIS APPROVAL CONSTITUTES THE BUYER/END USE CUSTOMER ACCEPTANCE OF THE MFG DESIGN CONCEPTS, ASSUMPTIONS, AND LOADING. (SECTION 4 AISC CODE AND MBMA 3.3.3)

ONCE THE BUYER/END USE CUSTOMER HAS SIGNED MFG APPROVAL PACKAGE THE PROJECT IS RELEASED FOR FABRICATION, AND CHANGES SHALL BE BILLED TO THE BUYER/END USE CUSTOMER INCLUDING MATERIAL, ENGINEERING AND OTHER COSTS. AN ADDITIONAL FEE MAY BE CHARGED IF THE PROJECT MUST BE MOVED FROM THE FABRICATION AND SHIPPING SCHEDULE.

THE BUYER/END USE CUSTOMER IS RESPONSIBLE FOR OVERALL PROJECT COORDINATION, ALL INTERFACE, COMPATIBILITY, AND DESIGN CONSIDERATIONS CONCERNING ANY MATERIALS NOT FURNISHED BY MFG AND MFG STEEL SYSTEMS ARE TO BE CONSIDERED AND COORDINATED BY THE BUYER/END USE CUSTOMER. SPECIFIC DESIGN CRITERIA CONCERNING THIS INTERFACE BETWEEN MATERIALS MUST BE FURNISHED BEFORE RELEASE FOR FABRICATION OR MFG ASSUMPTIONS WILL GOVERN (SECTION 4 AND COMMENTARY, AISC CODE OF STANDARD PRACTICE 9TH EDITION)

IT IS THE RESPONSIBILITY OF THE BUYER/END USE CUSTOMER TO INSURE THAT MFG PLANS COMPLIES WITH THE APPLICABLE REQUIREMENTS OF ANY GOVERNING BUILDING AUTHORITIES. THE SUPPLYING OF SEALED ENGINEERING DATA AND DRAWINGS FOR THE METAL BUILDING SYSTEM DOES NOT IMPLY OR CONSTITUTE AN AGREEMENT THAT MFG OR ITS DESIGN ENGINEER IS ACTING AS THE ENGINEER OF RECORD OR DESIGN PROFESSIONAL FOR A CONSTRUCTION PROJECT. THESE DRAWINGS ARE SEALED ONLY TO CERTIFY THE DESIGN OF THE STRUCTURAL COMPONENTS FURNISHED BY MFG.

THE BUYER/END USE CUSTOMER IS RESPONSIBLE FOR SETTING OF ANCHOR BOLTS AND ERECTION OF STEEL IN ACCORDANCE WITH MFG "FOR CONSTRUCTION" DRAWINGS ONLY. TEMPORARY SUPPORTS SUCH AS GUYS, BRACES, FALSE WORK, CRIBBING OR OTHER ELEMENTS REQUIRED FOR THE ERECTION OPERATION SHALL BE DETERMINED FURNISHED AND INSTALLED BY THE ERECTOR. NO ITEMS SHOULD BE PURCHASED FROM A PRELIMINARY SET OF DRAWINGS, INCLUDING ANCHOR BOLTS. USE ONLY FINAL "FOR CONSTRUCTION DRAWINGS" FOR THE USE. (SECTION 7 AISC CODE OF STANDARD PRACTICE, 9TH EDITION)

MFG IS RESPONSIBLE FOR THE DESIGN OF THE ANCHOR BOLT TO PERMIT THE TRANSFER OF FORCES BETWEEN THE BASE PLATE AND THE ANCHOR BOLT IN SHEAR, BEARING AND TENSION, BUT IS NOT RESPONSIBLE FOR THE TRANSFER OF ANCHOR BOLT FORCES TO THE CONCRETE OR THE ADEQUACY OF THE ANCHOR BOLT IN RELATION TO THE CONCRETE.

UNLESS OTHERWISE PROVIDED IN THE ORDER DOCUMENTS, MFG DOES NOT DESIGN AND IS NOT RESPONSIBLE FOR THE DESIGN, MATERIAL AND CONSTRUCTION OF THE FOUNDATION OR FOUNDATION EMBEDMENT. THE END USE CUSTOMER SHOULD ASSURE HIMSELF THAT ADEQUATE PROVISIONS ARE MADE IN THE FOUNDATION DESIGN FOR LOADS IMPOSED BY COLUMN REACTIONS OF THE BUILDING, OTHER IMPOSED LOADS, AND BEARING CAPACITY OF THE SOIL AND OTHER CONDITIONS OF THE BUILDING SITE.

IT IS RECOMMENDED THAT A PROFESSIONAL ENGINEER EXPERIENCED IN THE DESIGN OF SUCH STRUCTURES DESIGN THE ANCHORAGE AND FOUNDATION OF THE BUILDING. (SECTION A10 1996 MBMA LOW RISE BUILDING SYSTEMS MANUAL)

NORMAL ERECTION OPERATIONS INCLUDE THE CORRECTIONS OF MINOR MISFITS BY MODERATE AMOUNTS OF REAMING, CHIPPING, WELDING OR CUTTING, AND THE DRAWING OF ELEMENTS INTO LINE THROUGH THE USE OF DRIFT PINS. ERRORS WHICH CANNOT BE CORRECTED BY THE FOREGOING MEANS OR WHICH REQUIRE MAJOR CHANGES IN MEMBER CONFIGURATION ARE TO BE REPORTED IMMEDIATELY TO MFG BY THE BUYER/END USE CUSTOMER, TO ENABLE WHOEVER IS RESPONSIBLE EITHER TO CORRECT THE ERROR OR THE APPROVE THE MOST EFFICIENT AND ECONOMIC METHOD OF CORRECTION TO BE USED BY OTHERS. (SECTION 7 AISC CODE OF STANDARD PRACTICE, 9TH EDITION) NEITHER THE FABRICATOR NOR THE BUYER/END USE CUSTOMER WILL CUT, DRILL OR OTHERWISE ALTER HIS WORK, OR THE WORK OF OTHER TRADES, TO ACCOMMODATE OTHER TRADES, UNLESS SUCH WORK IS CLEARLY SPECIFIED. THE BUYER/END USE CUSTOMER IS RESPONSIBLE FOR FURNISHING COMPLETE INFORMATION AS TO MATERIALS, SIZE LOCATION AND NUMBER OF ALTERATIONS PRIOR TO PREPARATION OF SHOP DRAWINGS. (SECTION 7 AISC CODE OF STANDARD PRACTICE, 9TH EDITION)

SAFETY COMMITMENT
MFG HAS A COMMITMENT TO MANUFACTURE QUALITY BUILDINGS THAT CAN BE SAFELY ERECTED. HOWEVER, THE SAFETY COMMITMENT AND JOB SITE PRACTICES OF THE ERECTOR ARE BEYOND THE CONTROL OF MFG. IT IS STRONGLY RECOMMENDED THAT SAFE WORKING CONDITIONS AND ACCIDENT PREVENTION PRACTICES ARE THE TOP PRIORITY OF ANY JOB SITE. LOCAL, STATE, AND FEDERAL SAFETY AND HEALTH STANDARDS SHOULD ALWAYS BE FOLLOWED TO HELP INSURE WORKERS SAFETY. MAKE CERTAIN ALL EMPLOYEES KNOW THE SAFEST AND MOST PRODUCTIVE WAY OF ERECTING A BUILDING. ALL EMPLOYEES SHOULD KNOW EMERGENCY PROCEDURES. DAILY MEETINGS HIGHLIGHTING SAFETY PROCEDURES ARE ALSO RECOMMENDED. THE USE OF HARD HATS, RUBBER SOLE SHOES FOR ROOF WORK, PROPER EQUIPMENT FOR HANDLING MATERIAL, AND SAFETY NETS WHERE APPLICABLE, ARE RECOMMENDED.

NOTES: APPLIES TO ALL ELEVATIONS
1. DO NOT CUT, REMOVE OR RELOCATE GIRTS OR X-BRACING. NO ADDITIONAL OPENINGS ALLOWED WITHOUT WRITTEN APPROVAL FROM THE STEEL BUILDING MANUFACTURER.

2. HARDWARE SUCH AS WINDOWS, OVERHEAD DOORS, AND ASSOCIATED ATTACHMENTS THAT ARE AND ASSOCIATED ATTACHMENTS THAT ARE SUPPLIED BY OTHERS MUST HAVE THE SAME LEVEL OF WIND RESISTANCE AS WALL PANELS.

3. WORKERS SHALL NOT HAVE THEIR WEIGHT ON FRAMES OR INDIVIDUAL COLUMNS UNTIL THEY HAVE BEEN SECURED WITH GIRTS AND CROSS BRACING.

NOTES: APPROVAL DRAWINGS: * APPROVAL ORDERS MUST BE RELEASED FOR FABRICATION WITHIN FIVE (5) CALENDAR DAYS AFTER THE SUBMITTED DRAWINGS ARE ISSUED OR THEY WILL BE SUBJECT TO ANY CURRENT PRICE INCREASES. SPECIAL ATTENTION SHOULD BE GIVEN IN APPROVING DIMENSIONS AND/OR DETAILS.

BUILDERS RESPONSIBILITIES
THE BUYER / END USER / BUILDER MUST SECURE ALL REQUIRED APPROVALS AND PERMITS FROM THE APPROPRIATE AGENCY AS REQUIRED. APPROVAL OF MFG DRAWINGS AND CALCULATIONS INDICATES THAT MFG HAS CORRECTLY INTERPRETED AND APPLIED THE REQUIREMENTS OF THE CONTRACT DRAWINGS AND SPECIFICATIONS. (SECT. 4.2.1 AISC CODE OF STANDARD PRACTICE, 9TH EDITION) WHERE DISCREPANCIES EXIST BETWEEN MFG STRUCTURAL STEEL PLANS AND THE PLANS OF OTHER TRADES, THE STRUCTURAL STEEL PLANS WILL GOVERN. (SECT. 3.3 AISC CODE OF STANDARD PRACTICE, 9TH EDITION). DESIGN CONSIDERATIONS OF ANY MATERIALS IN THE STRUCTURE WHICH ARE NOT FURNISHED BY MFG ARE THE RESPONSIBILITY OF THE BUILDER AND ENGINEERS OTHER THAN MFG ENGINEERING UNLESS SPECIFICALLY INDICATED. THE BUYER/END USE CUSTOMER IS RESPONSIBLE FOR ALL ERECTION OF STEEL AND ASSOCIATED WORK IN COMPLIANCE WITH MFG "CONSTRUCTION DRAWINGS".

MFG 'S' STANDARD PRODUCT SPECIFICATIONS APPLY AND UNLESS STIPULATED OTHERWISE IN THE CONTRACT DOCUMENTS, MFG 'S' DESIGN, FABRICATION, QUALITY CRITERIA STANDARDS AND TOLERANCES WILL GOVERN THE WORK. IN CASE OF DISCREPANCIES BETWEEN MFG 'S' STRUCTURAL PLANS AND PLANS FOR OTHER TRADES MFG 'S' PLANS SHALL GOVERN.

IT IS THE RESPONSIBILITY OF THE BUYER/END USE CUSTOMER TO OBTAIN APPROPRIATE APPROVALS AND NECESSARY PERMITS FROM CITY, COUNTY, STATE, OR FEDERAL AGENCIES, AS REQUIRED. APPROVAL OF METAL MFG 'S' DRAWINGS CONSTITUTES THE BUYER/END USE CUSTOMER'S ACCEPTANCE OF MFG 'S' INTERPRETATION OF THE CONTRACT PURCHASE ORDER.

ONCE THE BUYER/END USE CUSTOMER OR A/E FIRM HAS SIGNED MFG 'S' APPROVAL PACKAGE, CHANGES FROM THE PURCHASE ORDER BY THE BUILDER WILL BE BILLED TO THE BUYER/END USE CUSTOMER FOR MATERIAL, ENGINEERING AND HANDLING FEES. SUCH CHANGES MAY CAUSE THE PROJECT TO BE MOVED FROM THE FABRICATION AND / OR SHIPPING SCHEDULE. A PENALTY FEE MAY BE CHARGED IF THE PROJECT MUST BE MOVED FROM THE FABRICATION AND / OR SHIPPING SCHEDULE.

THE BUYER/END USE CUSTOMER OR A/E FIRM IS RESPONSIBLE FOR THE OVERALL PROJECT CONDITION. ALL INTERFACE AND COMPATIBILITY CONCERNING ANY MATERIALS NOT FURNISHED BY MFG ARE TO BE CONSIDERED AND COORDINATED BY THE BUYER/END USE CUSTOMER OR A/E FIRM. MFG ASSUMPTIONS SHALL ALWAYS GOVERN.

THE BUYER/END USE CUSTOMER IS RESPONSIBLE TO INSURE THAT ALL OTHER PROJECT PLANS AND SPECIFICATIONS COMPLY WITH THE APPLICABLE REQUIREMENTS OF ANY GOVERNING BUILDING AUTHORITY. SUPPLYING DRAWINGS BY MFG DOES NOT IMPLY OR CONSTITUTE AN AGREEMENT THAT MFG OR ITS DESIGN ENGINEER IS ACTING AS THE ENGINEER OF RECORD OR DESIGN PROFESSIONAL FOR THE CONSTRUCTION PROJECT. THESE DRAWINGS AND DESIGN DATA ARE FURNISHED BY MFG IN COMPLIANCE WITH ALL REQUIREMENTS OF THE PURCHASE ORDER.

THE BUYER/END USE CUSTOMER IS RESPONSIBLE FOR SETTING OF ANCHOR BOLTS AND ERECTION OF STEEL BUILDING COMPONENTS IN ACCORDANCE WITH MFG 'S' "FOR CONSTRUCTION" DRAWINGS ONLY. TEMPORARY SUPPORTS OR BRACING REQUIRED FOR THE BUILDING ERECTION WILL BE THE RESPONSIBILITY OF THE ERECTOR TO DETERMINE, FURNISH, AND INSTALL. MFG DOES NOT WARRANT STRUCTURAL INTEGRITY OF ANY COMPONENTS FIELD MODIFIED OR DESIGNED AND FABRICATED BY OTHERS. NEITHER DO WE ACCEPT DESIGN RESPONSIBILITY FOR THE EFFECTS NON STANDARD COMPONENTS DESIGNED BY OTHERS MAY HAVE ON THE SYSTEM IN GENERAL.

PRIMER
SHOP PRIMER PAINT IS A RUST INHIBITIVE PRIMER, WHICH MEETS THE END PERFORMANCE OF FEDERAL SPECIFICATION TT-P-636 AND IS MFG RED OXIDE COLOR. THIS PAINT IS NOT INTENDED FOR LONG-TERM EXPOSURE TO THE ELEMENTS. MFG IS NOT RESPONSIBLE FOR ANY DETERIORATION OF THE SHOP PRIMER PAINT AS A RESULT OF IMPROPER HANDLING AND/OR STORAGE. MFG SHALL NOT BE RESPONSIBLE FOR ANY FIELD APPLIED PAINT AND/OR COATINGS. (SECTION 6.5 AISC CODE OF STANDARD PRACTICE 9TH EDITION) NORMAL THICKNESS OF PRIMER SHALL BE 1 MIL UNLESS OTHERWISE SPECIFIED IN CONTRACT DOCUMENTS.

GALVANIZED OR SPECIAL COATINGS
SEE CONTRACT DOCUMENTS.

ALL BOLTS ARE 0' 0-1/2" DIA. X 0'-1" A307 EXCEPT:

- A) EAVE STRUT CONNECTION - 1/2" X 0'-1-1/2" A307
- B) END WALL RAFTER SPLICE - 5/8" X 0'-1-3/4" A325-N
- C) END WALL COL/RAFT CONNECTION - 1/2" X 0' - 1-1/4" A325-N
- D) MAIN FRAME CONNECTIONS - SEE CROSS SECTION

A325 BOLT TIGHTENING REQUIREMENTS
ALL HIGH STRENGTH BOLTS ARE A325-N UNLESS NOTED OTHERWISE.

STRUCTURAL BOLTS SHALL BE TIGHTENED BY THE TURN-OF-THE-NUT METHOD IN ACCORDANCE WITH THE 9TH EDITION AISC "SPECIFICATION FOR STRUCTURAL JOINTS" USING ASTM A 325 OR A490 BOLTS, WHEN SPECIFICALLY REQUIRED. A325-N BOLTS ARE SUPPLIED WITHOUT WASHER UNLESS NOTED ON THE DRAWINGS AS PROVIDED BY MFG.

ALL BOLTED CONNECTIONS UNLESS NOTED ARE DESIGNED AS BEARING TYPE CONNECTIONS WITH THREADS NOT EXCLUDED FROM THE SHEAR PLANE.

CLOSURE STRIPS ARE FURNISHED ONLY IF NOTED ON SHIPPING DOCUMENTS

INSIDE - UNDER ROOF PANELS AT EAVE
OUTSIDE - BETWEEN END WALL PANELS AND RAKE TRIM
UNDER CONTINUOUS RIDGE VENT SKIRTS

ERECTION NOTE:
ALL BRACING, STRAPPING, & BRIDGING SHOWN AND PROVIDED BY MFG FOR THIS BUILDING IS REQUIRED AND SHALL BE INSTALLED BY THE ERECTOR AS A PERMANENT PART OF THE STRUCTURE. IF ADDITIONAL BRACING IS REQUIRED FOR STABILITY DURING ERECTION, IT SHALL BE THE ERECTOR'S RESPONSIBILITY TO DETERMINE THE AMOUNT OF SUCH BRACING AND TO PROCURE AND INSTALL AS NEEDED.

ERECTION AND UNLOADING NOT BY MFG

SHORTAGES
ANY CLAIMS OR SHORTAGES BY BUYER MUST BE MADE TO MFG WITHIN SEVEN (7) DAYS AFTER DELIVERY, OR SUCH CLAIMS SHALL BE CONSIDERED WAIVED BY THE CUSTOMER AND DISALLOWED.

CORRECTIONS OF ERRORS AND REPAIRS (MBMA 6.10)
CLAIMS FOR CORRECTION OF ALLEGED MISFITS WILL BE DISALLOWED UNLESS MFG SHALL HAVE RECEIVED PRIOR NOTICE THEREOF AND ALLOWED REASONABLE INSPECTION OF SUCH MISFITS. THE CORRECTION OF MINOR MISFITS BY THE USE OF DRIFT PINS TO DRAW THE COMPONENTS INTO LINE, MODERATE AMOUNTS OF REAMING, CHIPPING, SHIMMING AND CUTTING, AND THE REPLACEMENT OF MINOR SHORTAGES OF MATERIAL ARE A NORMAL PART OF ERECTION AND ARE NOT SUBJECT TO CLAIM. NO PART OF THE BUILDING MAY BE RETURNED FOR ALLEGED MISFITS WITHOUT THE PRIOR APPROVAL OF MFG.

BUILDING SPECIFICATIONS
THE STRUCTURE UNDER THIS CONTRACT HAS BEEN DESIGNED AND DETAILED FOR THE LOADS AND CONDITIONS STIPULATED IN THE CONTRACT AND SHOWN ON THESE DRAWINGS. ANY ALTERATIONS TO THE STRUCTURAL SYSTEM OR REMOVAL OF ANY COMPONENT PARTS OR THE ADDITION OF OTHER CONSTRUCTION MATERIALS OR LOADS MUST BE DONE UNDER THE ADVICE OF A REGISTERED ARCHITECT, CIVIL OR STRUCTURAL ENGINEER. MFG WILL NOT ASSUME RESPONSIBILITY FOR ANY LOADS NOT INDICATED.

WARNING
INSTALL THIS BUILDING AND ALL ITS PARTS PER THESE DRAWINGS. NO CHANGES SHOULD BE MADE TO THIS BUILDING SYSTEM UNLESS APPROVED IN WRITING BY THE MANUFACTURER'S ENGINEERS. UNAPPROVED CHANGES COULD RESULT IN UNSAFE BUILDING DESIGN AND COULD ENDANGER PUBLIC SAFETY.

IN NO CASE SHOULD GALVALUME STEEL PANELS BE USED IN CONJUNCTION WITH LEAD OR COPPER. BOTH LEAD AND COPPER HAVE HARMFUL CORROSIVE EFFECTS ON THE GALVALUME ALLOY COATING WHEN THEY ARE IN CONTACT WITH GALVALUME STEEL PANELS. EVEN RUN-OFF FROM COPPER FLASHING, WIRING, OR TUBING ONTO GALVALUME SHOULD BE AVOIDED.

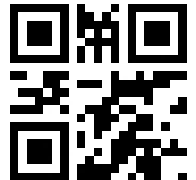

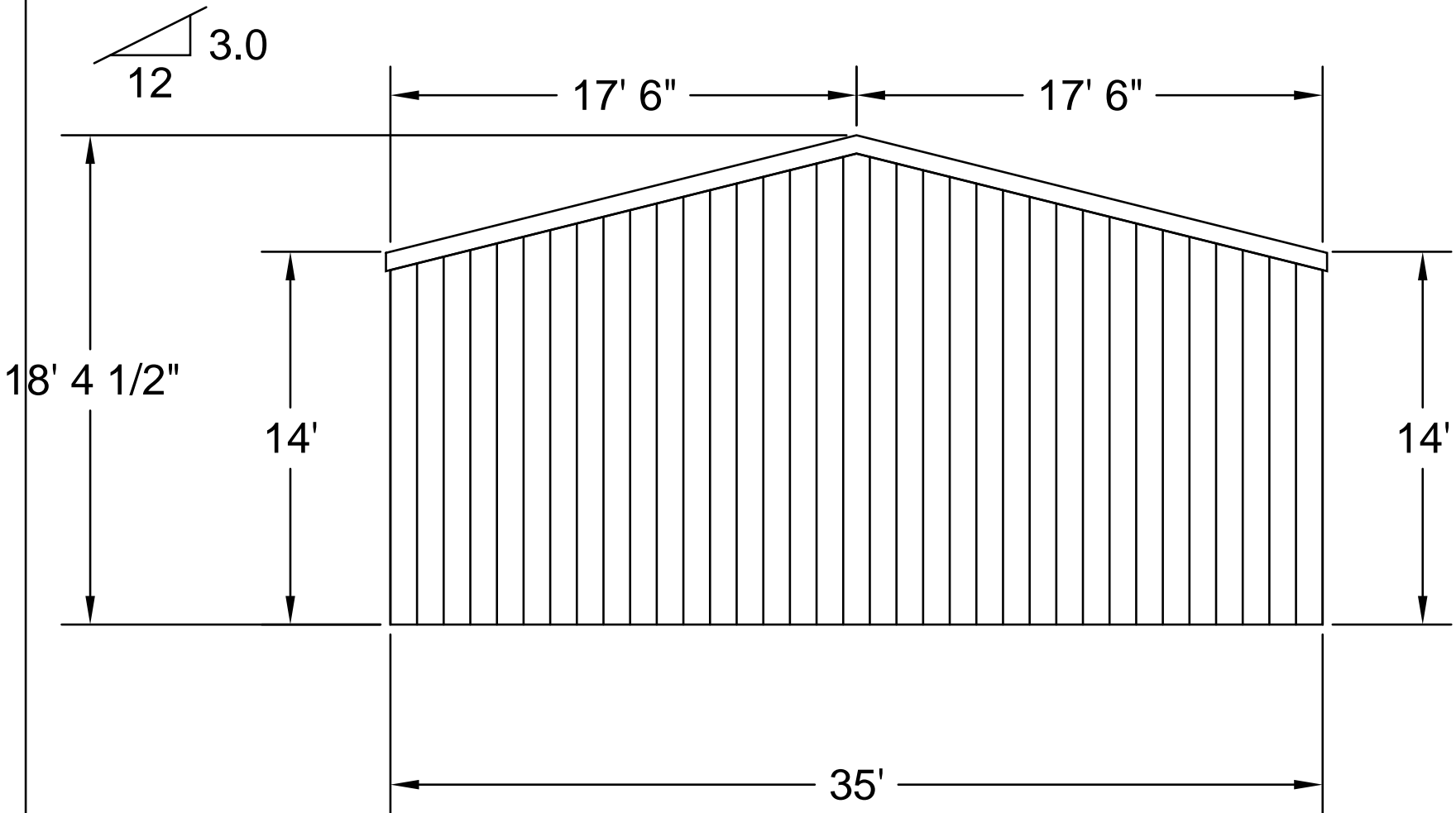

Physical Address
4340 I-10 West
Seguin TX 78155
888-798-8794
888-377-4267 fax

Corporate Office
P.O. Box 1079
Seguin TX 78156
888-798-8794
888-377-4267 fax

Check One:

- Approved as designed
 Approved as noted
 (subject to varification)

Approved by: _____
 End Use Customer Signature

PROJECT: 35x70 Special	JOB NO.: 681816
DESCRIPTION: Left end wall	
SIZE: 35' x 70' x eave height: 14', peak height: 18' 4 1/2"	
CUSTOMER: Building Specials	
LOCATION: Seguin, 78155	
DATE: 11/17/2009	REV. NO.: 5
SHEET NO.: 3/7	

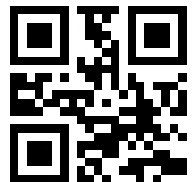

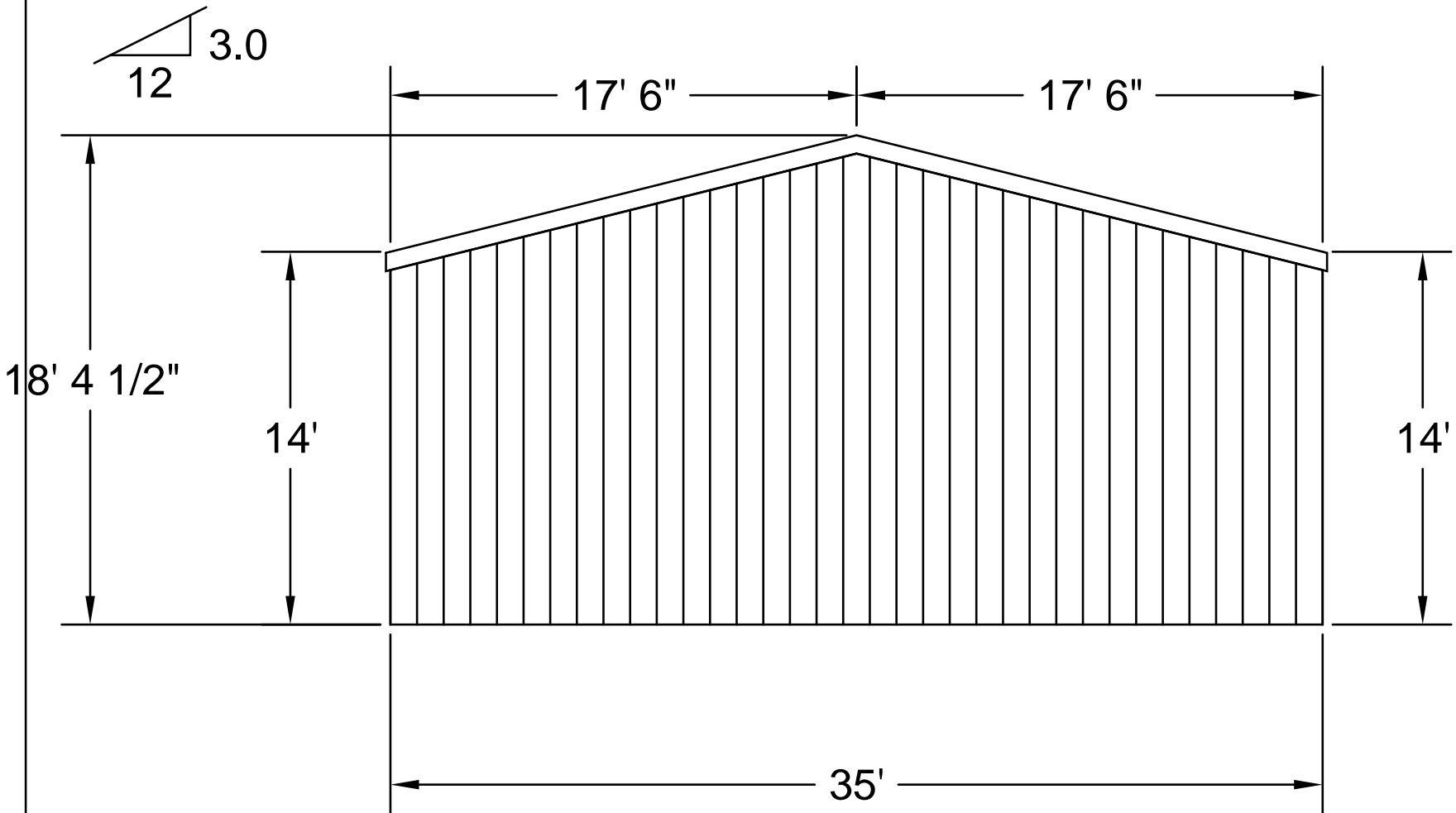

Physical Address
4340 I-10 West
Seguin TX 78155
888-798-8794
888-377-4267 fax

Corporate Office
P.O. Box 1079
Seguin TX 78156
888-798-8794
888-377-4267 fax

Check One:

- Approved as designed
- Approved as noted
(subject to verification)

Approved by: _____
End Use Customer Signature

PROJECT: 35x70 Special

JOB NO.: 681816

DESCRIPTION: Right end wall

SIZE: 35' x 70' x eave height: 14', peak height: 18' 4 1/2"

CUSTOMER: Building Specials

LOCATION: Seguin, 78155

DATE: 11/17/2009

REV. NO.: 5

SHEET NO.: 4/7

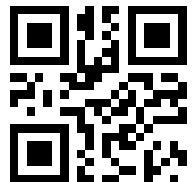

ID	Description
d1	12' x 12'

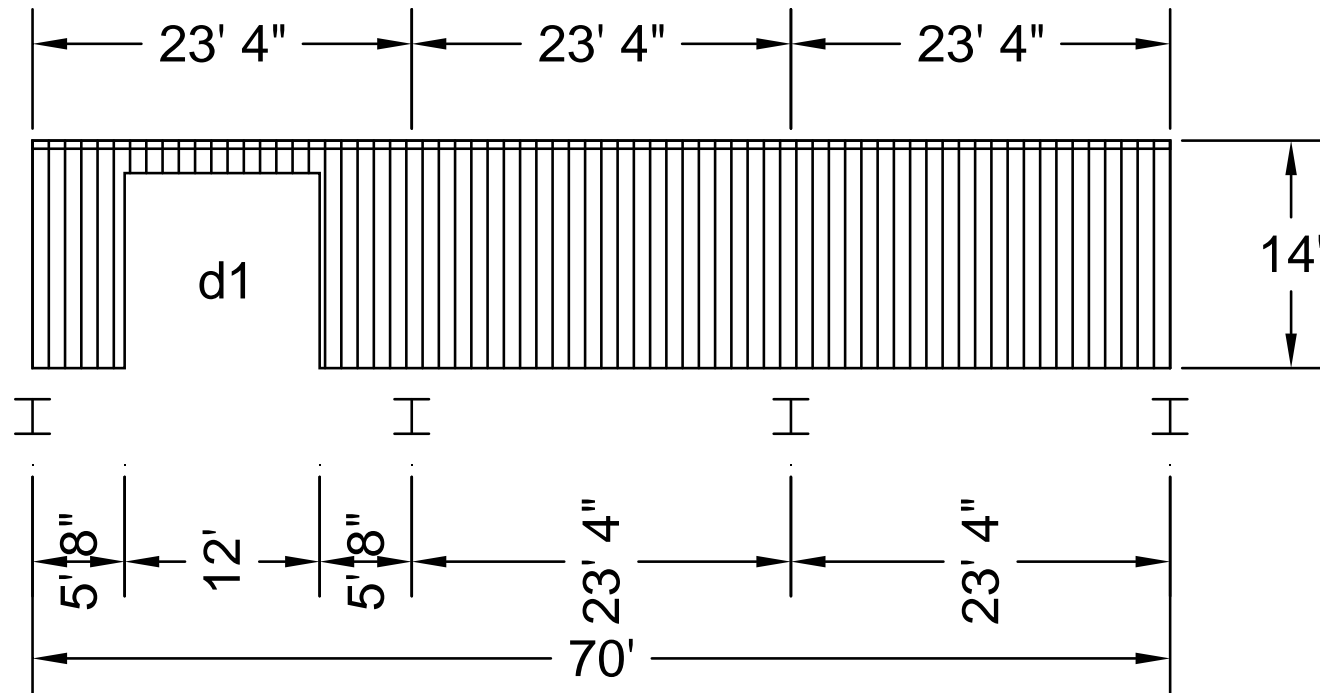

Physical Address
4340 I-10 West
Seguin TX 78155
888-798-8794
888-377-4267 fax

Corporate Office
P.O. Box 1079
Seguin TX 78156
888-798-8794
888-377-4267 fax

Check One:

- Approved as designed
 Approved as noted
(subject to verification)

Approved by: _____

End Use Customer Signature

PROJECT: 35x70 Special

JOB NO.: 681816

DESCRIPTION: Front side wall

SIZE: 35' x 70' x eave height: 14', peak height: 18' 4 1/2"

CUSTOMER: Building Specials

LOCATION: Seguin, 78155

DATE: 11/17/2009

REV. NO.: 5

SHEET NO.: 5/7

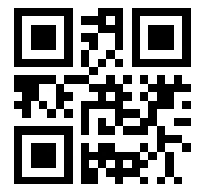

ID	Description
d1	12' x 12'

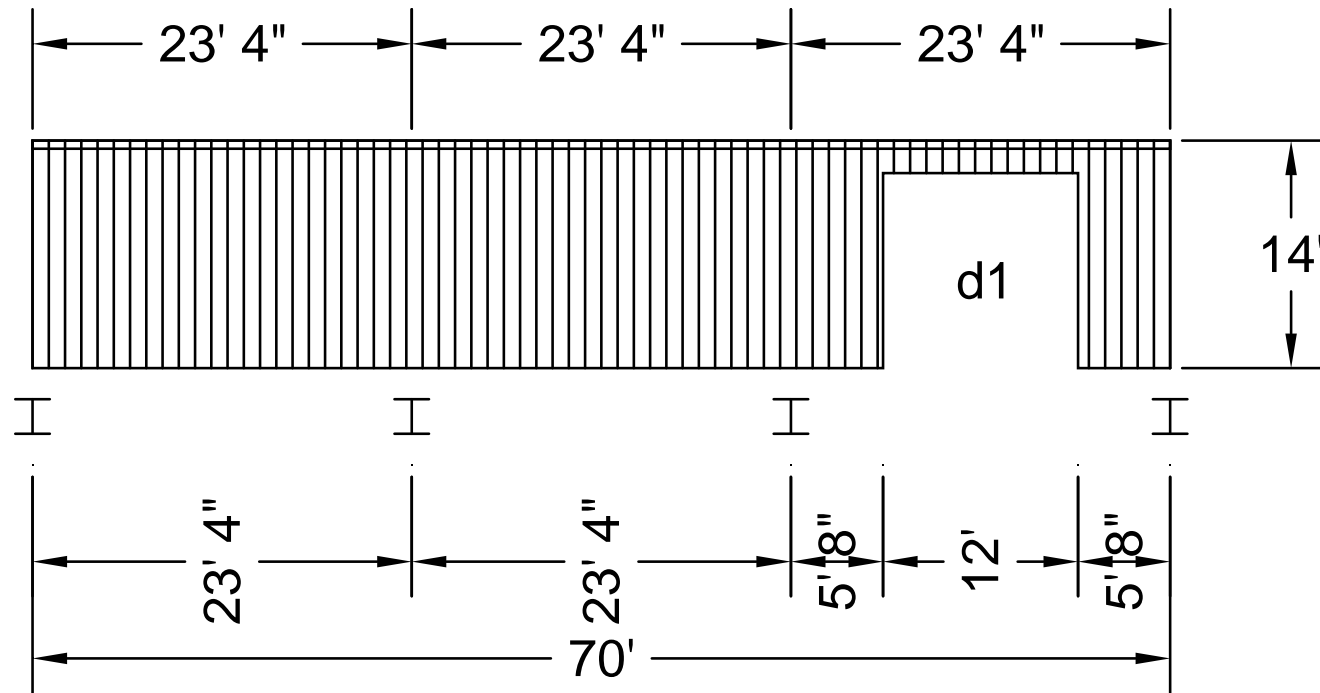

Physical Address
4340 I-10 West
Seguin TX 78155
888-798-8794
888-377-4267 fax

Corporate Office
P.O. Box 1079
Seguin TX 78156
888-798-8794
888-377-4267 fax

Check One:

- Approved as designed
 Approved as noted
(subject to varification)

Approved by: _____
 End Use Customer Signature

PROJECT: 35x70 Special	JOB NO.: 681816
DESCRIPTION: Back side wall	
SIZE: 35' x 70' x eave height: 14', peak height: 18' 4 1/2"	
CUSTOMER: Building Specials	
LOCATION: Seguin, 78155	
DATE: 11/17/2009	REV. NO.: 5
SHEET NO.: 6/7	

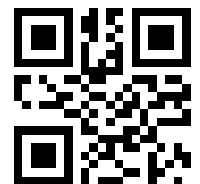

ID	Description
d1	12' x 12'
d2	12' x 12'

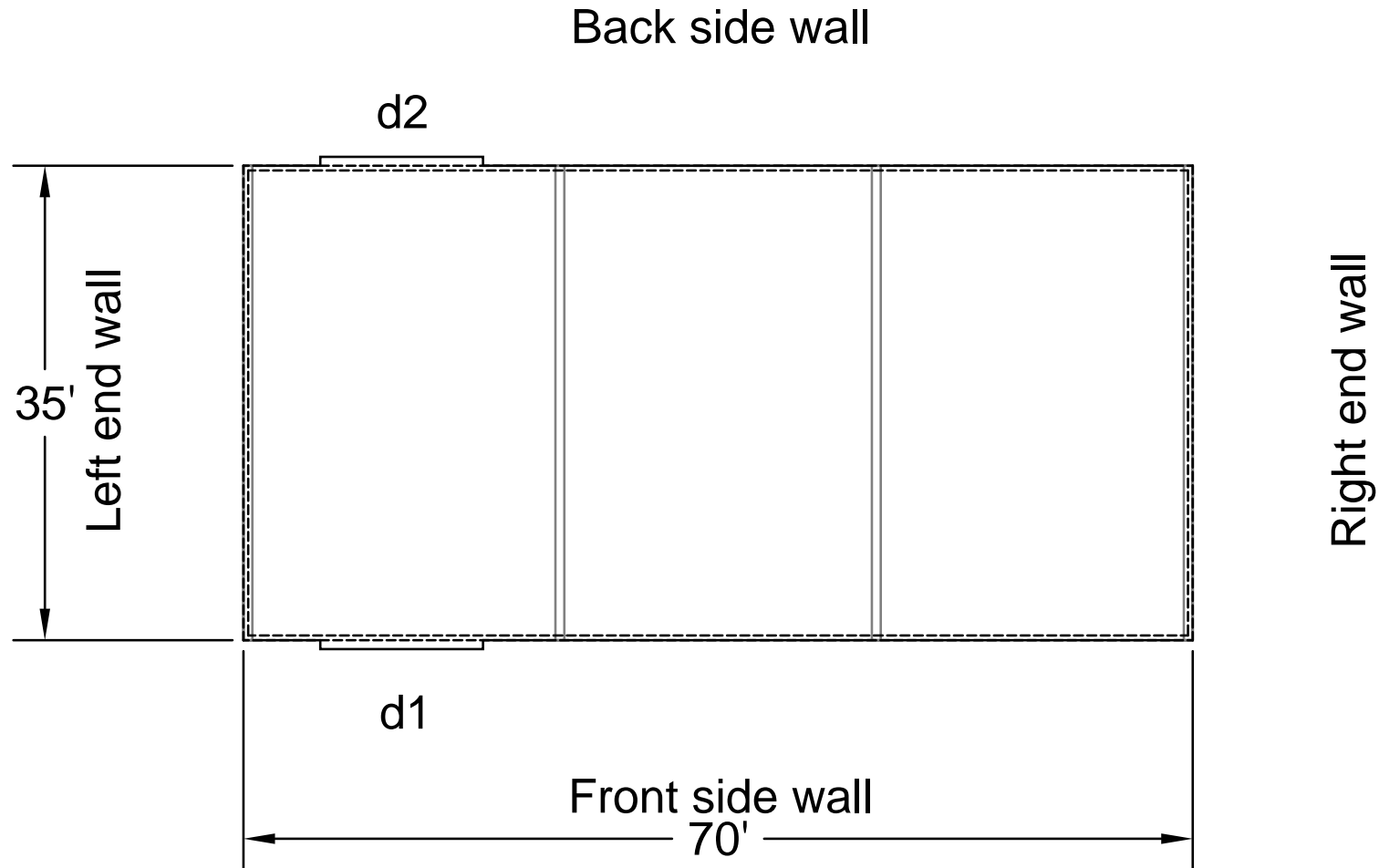

Physical Address
4340 I-10 West
Seguin TX 78155
888-798-8794
888-377-4267 fax

Corporate Office
P.O. Box 1079
Seguin TX 78156
888-798-8794
888-377-4267 fax

Check One:

- Approved as designed
 Approved as noted
(subject to verification)

Approved by: _____
 End Use Customer Signature

PROJECT: 35x70 Special	JOB NO.: 681816
DESCRIPTION: Floor plan	
SIZE: 35' x 70' x eave height: 14', peak height: 18' 4 1/2"	
CUSTOMER: Building Specials	
LOCATION: Seguin, 78155	
DATE: 11/17/2009	REV. NO.: 5
SHEET NO.: 7/7	

